

If installation on the series anchorage points is impossible for the shoulder and/or crotch straps, new anchorage points must be installed on the shell or the chassis, as near as possible to the centre-line of the rear wheels for the shoulder straps. The shoulder straps may also be fixed to the safety rollcage or to a reinforcement bar by means of a loop, and may also be fixed to the top anchorage points of the rear belts, or be fixed or leaning on a transversal reinforcement welded to the backstays of the rollbar. In this case, the use of a transversal reinforcement is subject to the conditions:

- The transversal reinforcement shall be a tube measuring at least 38 mm x 2.5 mm or 40 mm x 2 mm, made from cold drawn seamless carbon steel, with a minimum yield strength of 350 N/mm².

- The height of this reinforcement must be such that the shoulder straps, towards the rear, are directed downward with an angle of between 10° and 45° to the horizontal from the rim of the backrest, an angle of 10° being recommended.

- The straps may be attached by looping or by screws, but in the latter case an insert must be welded for each mounting point (see drawings 253-17C and 253-53 for the dimensions). These inserts will be positioned in the reinforcement tube and the straps will be attached to them using bolts of M12 8.8 or 7/16UNF specification.

- Each anchorage point must be able to withstand a load of 2000 daN, or 980 daN for the crotch straps. In the case of one anchorage point for two straps, the load considered will be equal to the sum of the required loads.

- For each new anchorage point created, a steel reinforcement plate with a surface area of at least 40 cm² and a thickness of at least 3 mm must be used.

- Principles of mounting to the chassis / monocoque:
 - 1) General mounting system: see drawing 253-43.
 - 2) Shoulder strap mounting: see drawing 253-44.
 - 3) Crotch strap mounting: see drawing 253-45.

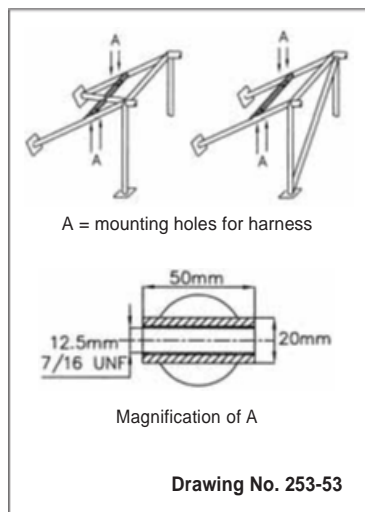
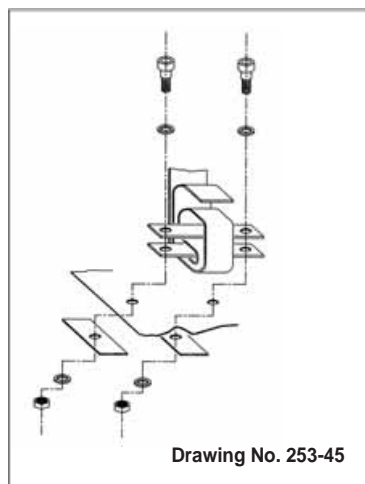

6.3 Use

A safety harness must be used in its homologation configuration without any modifications or removal of parts, and in conformity with the manufacturer's instructions. The effectiveness and longevity of safety belts are directly related to the manner in which they are installed, used and maintained. The belts must be replaced after every severe collision, and whenever the webbing is cut, frayed or weakened due to the actions of chemicals or sunlight. They must also be replaced if metal parts or buckles are bent, deformed or rusted. Any harness which does not function perfectly must be replaced.

TRS Motorsport (Part of Certex UK)
 Unit C1, Harworth Industrial Estate, Bryans Close, Harworth, DN11 8RY UK
 Tel: 01302 750800 Email: sales@trs-motorsport.com www.trs-motorsport.com

A division of Certex Lifting Ltd.
 Registered Office: Certex Lifting Ltd, Unit C1, Harworth Ind. Estate, Harworth, DN11 8RY
 Registered in England No. 05304747

PRO / MAGNUM / NASCAR / SALOON CAR HARNESES INSTRUCTIONS FOR INSTALLATION AND USE

Relevant extracts concerning the installation and use of safety harnesses are printed on the inside of this Instruction, for information.

Install harness as shown in the diagrams below. If in doubt, contact supplying dealer or manufacturer.

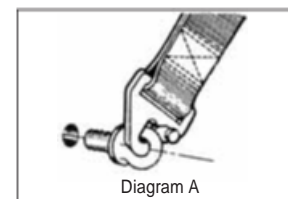
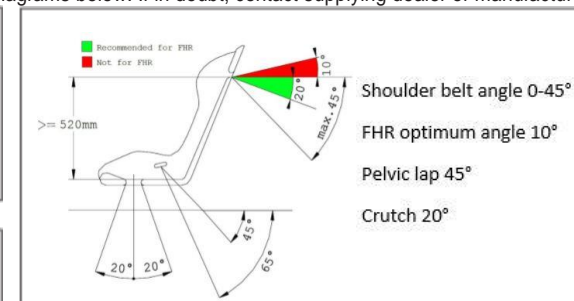
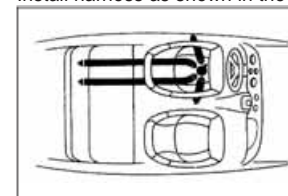

All mounting points must be capable of withstanding a minimum load of 4375lbs/2000kg. Ensure eye bolts are tight in their mountings and in line with the direction of load. Use packing washers if necessary - see diagram A

Roll Cage Wraparound Fixing

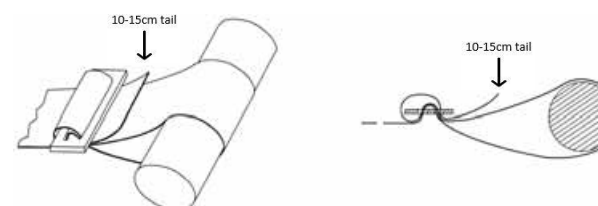

The initial adjustment of the length of the shoulder straps should be carried out at the time of installation. With the occupant in the normal seated position, adjust the rearmost portion of the shoulder strap/straps so that the two shoulder strap adjusters rest on the occupant's chest, approximately 25cms from the release buckle. This is done by passing the webbing through the two slots in the locking device/devices until the required length is obtained. It is important that, after this adjustment has been made, the locking device/devices should be moved as close as possible to the mounting hook, ensuring that the strap/straps remain the required length.

Inspect harnesses regularly for signs of wear or damage. Never allow the harness to come into contact with sharp edges which may cut or chafe the webbing, i.e. where straps pass through seats or cowlings. Never change or modify any part of the harness in any way.

When wearing the harnesses adjust all straps to be as tight as possible without being uncomfortable. Tighten lap straps first, then shoulder straps. Straps to mounting points should be

taut and in a straight line.

To tighten the lap and shoulder straps, pull the free end of the strap through the adjuster. To loosen, turn the adjuster at right angles to the strap and pull away from the release buckle.

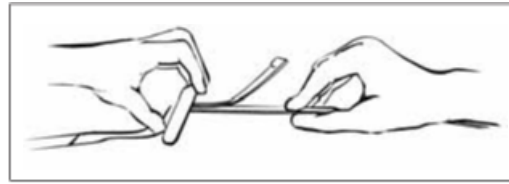

To fasten Aircraft systems, insert lap and shoulder tongues into their respective slots in the buckle until the click is heard. To release, rotate knob in either direction. For Nascar system see diagram below.

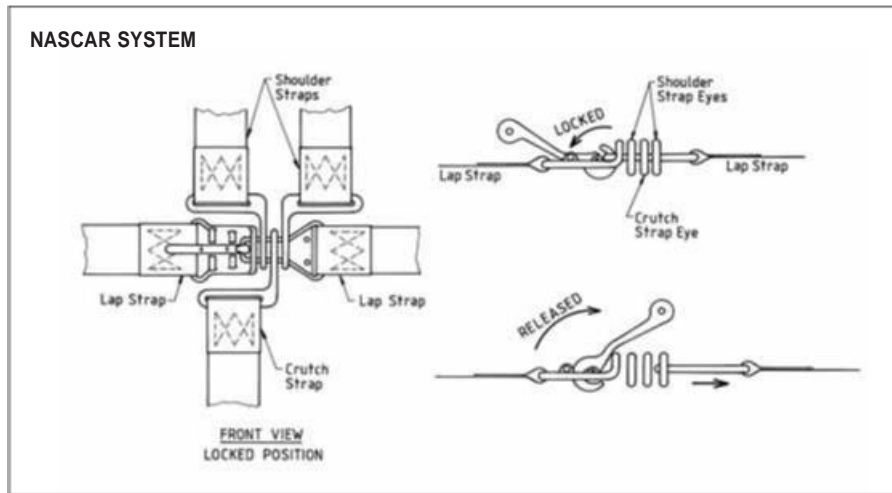

CARE AND MAINTENANCE

When not in use, the release buckle should be fastened and the straps tightened to remove slack.

The webbing and hardware of the harness may be cleaned by sponging with mild soap and water and allowing to air dry. Never immerse the release buckle or adjusters.

The effectiveness of the harness will be impaired if it is changed or altered in any way. If the harness becomes dis-assembled, it should be returned to the manufacturer for re-assembly.

The harness should be replaced following a severe impact, or when the webbing or hardware is damaged in any way, or it does not function properly.

WARNING - The effectiveness of this harness is directly related to the way in which it is installed, used and maintained. The user assumes that risk. No warranty, expressed or implied, is made as to its ability to protect against serious injury or death. See instructions for correct installation. In doubt, consult the Manufacturer. Harnesses should be returned to the Manufacturer for inspection once a year and replaced every two years. Harnesses should be replaced following an accident, or when the webbing or hardware is damaged in any way or does not function properly.

EXTRACTS FROM FIA REGULATIONS ARTICLE 253 - SAFETY EQUIPMENT

6.2 - Installation

A safety harness may be installed on the anchorage points of the series car. The recommended geometrical locations of the anchorage points are shown in drawing no 253-42.

In the downwards direction, the shoulder straps must be directed towards the rear and must be installed in such a way that they do not make an angle of more than 45° to the horizontal from the upper rim of the backrest, although it is recommended that this angle should not exceed 10°.

The maximum angles in relation to the centre-line of the seat are 20° divergent or convergent.

If possible, the anchorage point originally mounted by the car manufacturer on the C-pillar should be used.

Anchorage points creating a higher angle to the horizontal must not be used unless the seat meets the requirements of the FIA standard. In that case, the shoulder straps must be installed on the rear seat lap strap anchorage points originally mounted by the car manufacturer.

For a 4-point harness, the shoulder straps must be installed crosswise symmetrically about the centre-line of the front seat.

A safety harness must not be installed on a seat having no head restraint or having a backrest with integrated head restraint.

The lap and crotch straps should not pass over the sides of the seat but through the seat, in order to wrap and hold the pelvic region over the greatest possible surface. The lap straps must fit tightly in the bend between the pelvic crest and the upper thigh. Under no circumstances must they be worn over the region of the abdomen. Holes may be made in the series seat if this proves to be necessary in order to avoid such an occurrence. Care must be taken that the straps cannot be damaged through chafing against sharp edges.

Drawings relating to the installation of harnesses.

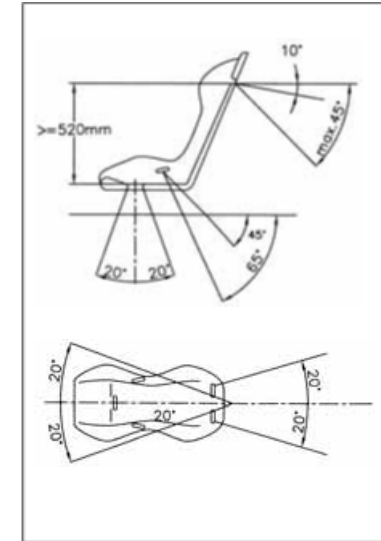

Drawing No. 253-42

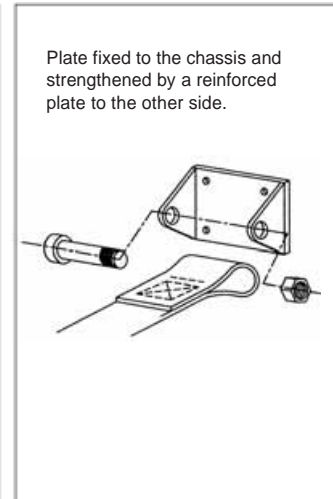
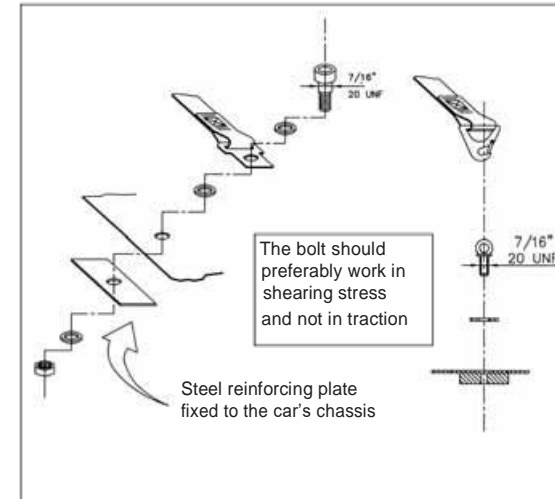

PLEASE NOTE: Harnesses homologated by the FIA, when installed into the car, will display the FIA Homologation Label on the users left shoulder strap.